

## **Laser Light Barrier Systems HLS**

### **for Applications in Severe Industrial Environments and Long Range Perimeter Protection**

#### **Features**

- Installation Distances up to 800 m
- Safe Class 1 Laser Product
- Alarm and Pre-Alarm Output
- Supply Voltage 24 VDC  
Optional 90 - 264 VAC
- Rugged Stainless Steel Design
- Double-walled Cooling Housing
- Protection Rating IP 65
- Armoured Silicone Cable



HLSseF121

## HEAVY DUTY LASER LIGHT BARRIER SYSTEM

HLS-03

### General Description

OPTEL's heavy duty laser light barrier systems HLS with a range of up to 800 m are suitable for long range perimeter protection and applications in severe industrial environments, where adverse conditions like dust, smoke, steam or heat prevail.

The laser light barrier system HLS-03 comprises a transmitter unit and a choice of three receiver units.

The supply voltage is either 24 VDC or optionally 90 - 264 VAC.

The transmitter unit contains an eye-safe semiconductor laser device, which emits light pulses at a fixed pulse repetition rate, as long as the supply voltage is applied.

When a system is set up and aligned, these light pulses are picked up by the highly sensitive photodetector in the light barrier receiver unit and the integrated alarm relay is switched to the 'Alarm Off' state.

If the connection between the transmitter and receiver is cut off by an object moving into the optical path, or if there is a technical defect in the electronics or in the power supply, the alarm relay switches to the 'Alarm On' state.

The use of a semiconductor laser transmitter and a highly sensitive photodetector guarantees reliable operation, even under extremely difficult conditions. Even high background illuminations, e.g. due to the sun or white hot steel, does not lead to a degradation of functionality.

For applications requiring a short response time, the receiver HLS-03T reacts in a fixed time of approx. 2 milliseconds.

The standard receiver HLS-03S enhances the advantages of the system, by offering the possibility to delay the activation of the alarm relay. By delaying the response time of the alarm relay, between approx. 10 milliseconds to about 1 second, it is possible to avoid false alarms and consequential costly interruptions of production due to the loss of a few inconsequential light pulses.

An additional increase in operational safety is offered by the receiver HLS-03K.

During operation in adverse environments, the optics of the transmitter and receiver units will be covered, in a not definable time, by a dust layer or a dirt/oil film which reduces the initially high power margin. When the received power then falls to near the detection threshold of the photodetector, even small changes in operating conditions might result in sufficient pulse losses to provoke false alarms and again costly interruptions of production.

To avoid this the HLS-03K receiver features an independent 'Pre-Alarm' function.

If the strength of the received optical signal falls below an individually adjustable threshold, well above the 'Alarm' threshold, an 'early warning' signal is activated, that can be used to alert maintenance staff.

By setting the 'Pre-Alarm' threshold with a sufficient margin to the fixed 'Alarm' threshold, false alarms can be avoided and maintenance cycles kept to a necessary minimum.

The careful selection of materials and components and the use of rugged stainless steel housings and armoured silicone cables with stainless steel braiding, ensures troublefree operation even under most severe conditions.

The cables are standardly non-detachable. Detachable cables with sturdy connectors are optionally available. For operation in areas of high ambient temperatures, all devices can be delivered in a special double-walled housing with pipe-fittings for the connection to an air or water cooling circuit.

### Laser Safety

The HLS-03 laser transmitters are eye-safe and do not emit hazardous laser radiation. There is no danger from the laser, even while looking directly into the laser with an optical instrument (telescope, binoculars, magnifying glass). The following label is located on top of the transmitter housing, to indicate that the HLS-03 light barrier transmitters units are Class 1 laser products as defined in IEC 60825-1 specifications.



### General Technical Data

Operating Range	max. approx. 800 m
Supply Voltage	<ul style="list-style-type: none"> <li>• 24 VDC ± 20% (max. 2 W)</li> </ul> Devices are protected against over-voltage (max. approx. 40 VDC), under-voltage and wrong polarity.
Optional	<ul style="list-style-type: none"> <li>• 90 - 264 VAC (max. 2VA)</li> </ul>
Power Consumption / Unit	max. approx. 2 W
Connecting Cable	Armoured Silicone Cable 0.75 mm <sup>2</sup>
Standard Cable Length	2 m (non-detachable)
Optional	Detachable cable
Protection Rating	IP65
Operating Temperature	-25 °C ... +60 °C
Weight Standard Housing	approx. 1.8 kg
Cool Jacket Housing	approx. 3.2 kg
Cooling	
Water Temperature	approx. 15 °C ... 30 °C
Rate of Flow	approx. 8 ... 10 l/min

# HEAVY DUTY LASER LIGHT BARRIER SYSTEM

HLS-03

## Technical Data Transmitter Unit HLS-03 / HLS-03T

Optical Transmitter	Semiconductor Laser Diode
Laser Classification (IEC 60825-1)	Class 1
Transmitter Lens Diameter	20 mm
Transmission Wavelength	850 / 904 nm
Transmitting Angle (Far Field)	approx. 8 mrad
Pulse Repetition Frequency	HLS-03 approx. 300 Hz HLS-03T approx. 1000 Hz
Peak Pulse Output Power	max. 1.3 W
Laser Pulse Width	max. 20 ns
Operation Indicator	Green LED
Supply Current (24 VDC)	max. approx. 25 mA
Connecting Cable	Armoured Silicone Cable 3 x 0.75 mm <sup>2</sup>
Cable Length (non-detachable)	2 m
Connector (optional)	6-contacts

## Electrical Connections 24 VDC (optional 90 - 264 VAC)

Lead Number or Colour	Connector Contact	Designation
1	1	Supply Voltage +24 VDC ± 20%
2	5	Supply Voltage Ground
Yellow-Green (YeGn)	6	Protective Ground (Internally connected to Supply Voltage Ground)
1 (+ red Ring)	2	VAC - L1 Live (optional)
2 (+ red Ring)	4	VAC - N Neutral (optional)

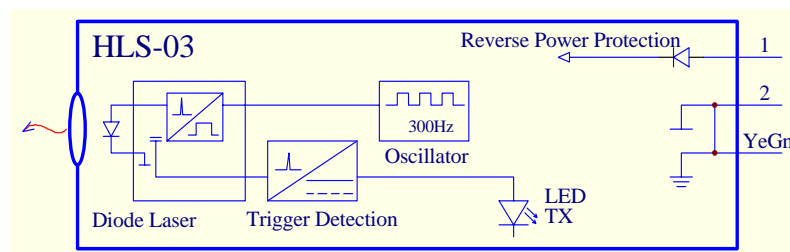

## HEAVY DUTY LASER LIGHT BARRIER SYSTEM

HLS-03

### Technical Data Receiver Unit HLS-03S

Receiver Element	Photodiode
Detection Wavelength	850 - 904 nm
Minimal Detectable Power	approx. 2 $\mu$ W
Receiver Lens Diameter	38 mm
Field of View (Far Field)	nom. approx. 50 mrad
Adjustable Alarm Response Time (incl. relay release time of approx. 2 ms)	min. approx. 10 to 15 ms max. approx. 800 to 1100 ms
'Alarm' Output Pulse Width	min. approx. 300 to 400 ms
Alarm Relay	
Activation/Permanent/Cut-off Current	max. 5 / 2 / 2 A
Cut-off Voltage	max. 30 VDC / 125 VAC
Cut-off Power	max. 60 W / 125 VA
Operation Indicator 'P'	Green LED
Alarm Indicator 'A'	Red LED
Supply Current (24 VDC)	max. approx. 50 mA
Connecting Cable	Armoured Silicone Cable 6 x 0.75 mm <sup>2</sup>
Cable Length (non-detachable)	2 m
Connector (optional)	9-contacts

### Electrical Connections

Lead Number or Colour	Connector Contact	Designation
1	1	Supply Voltage +24 VDC $\pm$ 20%
2	2	Supply Voltage Ground
3	3	Alarm Relay (CO) Change-Over Contact
4	4	Alarm Relay (NO) Normally-Open Contact
5	5	Alarm Relay (NC) Normally-Closed Contact (Contact is closed in alarm mode or when no supply voltage is applied)
Yellow-Green (YeGn)	9	Protective Ground (Internally connected to Supply Voltage Ground)
1 (+ Red ring)	8	VAC - L1 Live (optional)
2 (+ Red ring)	7	VAC - N Neutral (optional)

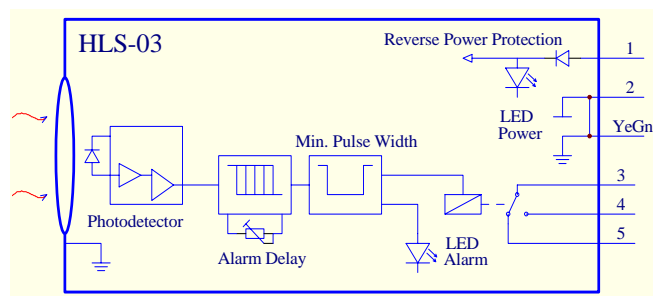

Drawings show 'Alarm'-Relay in 'Alarm'-mode or with no supply voltage applied.

## HEAVY DUTY LASER LIGHT BARRIER SYSTEM

HLS-03

### Technical Data Receiver Unit HLS-03K

Receiver Element	Photodiode
Detection Wavelength	850 - 904 nm
Minimal Detectable Power	approx. 2 $\mu$ W
Receiver Lens Diameter	38 mm
Field of View (Far Field)	nom. approx. 50 mrad
Adjustable Alarm Response Time	min. approx. 10 to 15 ms
(incl. relay release time of approx. 2 ms)	max. approx. 800 to 1100
'Alarm' Output Pulse Width	min. approx. 300 to 400 ms
'Pre-Alarm' Output	
Adjustable Threshold Range	26 dB
Received Optical Power Trigger Level	min. approx. 8 $\mu$ W
	max. approx. 4 mW
Operating Current	approx. 30 mA
Voltage Level 'Contact'	approx. +22 VDC (without load)
Voltage Level 'Pre-Alarm'	0 V
Alarm Relay	
Activation/Permanent/Cut-off Current	max. 5 / 2 / 2 A
Cut-off Voltage	max. 30 VDC / 125 VAC
Cut-off Power	max. 60 W / 125 VA
Operation Indicator 'P'	Green LED
Alarm Indicator 'A'	Red LED
Supply Current (24 VDC)	max. approx. 50 mA
Connecting Cable	Armoured Silicone Cable 7 x 0.75 mm <sup>2</sup>
Cable Length (non-detachable)	2 m
Connector (optional)	9-contacts

### Electrical Connections

Lead Number or Colour	Connector Contact	Designation
1	1	Supply Voltage +24 VDC $\pm$ 20%
2	2	Supply Voltage Ground
3	3	Alarm Relay (CO) Change-Over Contact
4	4	Pre-Alarm Signal Output +22 V / 0 V
5	5	Alarm Relay (NC) Normally-Closed Contact (Contact is closed in alarm mode or when no supply voltage is applied)
6	6	Alarm Relay (NO) Normally-Open Contact
Yellow-Green (YeGn)	9	Protective Ground (Internally connected to Supply Voltage Ground)
1 (+ red Ring)	8	VAC - L1 Live (optional)
2 (+ red Ring)	7	VAC - N Neutral (optional)

# HEAVY DUTY LASER LIGHT BARRIER SYSTEM

HLS-03

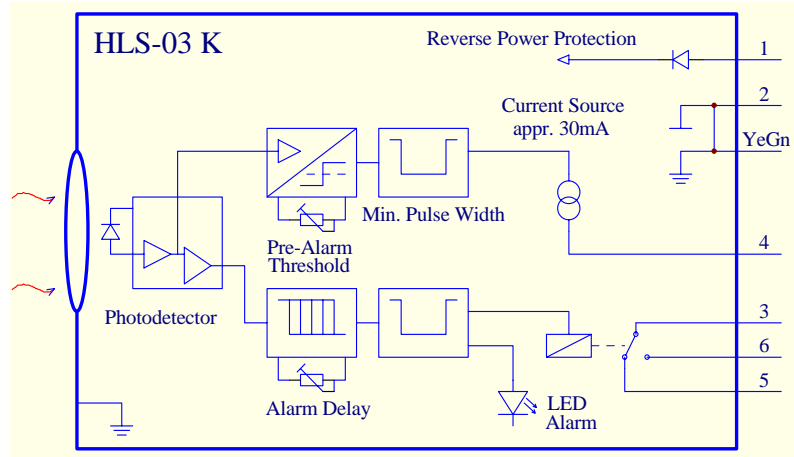

Drawing shows 'Alarm'-Relay in 'Alarm'-mode or with no supply voltage applied.

## Alarm Relay Response Times

Starting from an operating light barrier system:		
Transmitter supply voltage switched off till 'Alarm On'	approx.	20 to 24 ms
Transmitter supply voltage switched on till 'Alarm Off'	approx.	5 to 23 ms
Receiver supply voltage switched off till 'Alarm On'	approx.	18 ms
Receiver supply voltage switched on till 'Alarm Off'	approx.	400 ms

## Device Labels



optel Optical Communication  
Tel 040 830 99 360 Fax 040 830 99 362  
Service@optel.de www.optel.com

Type: HLS-03 Transmitter  
Ser. No.: 123 456 789 /1  
Power Supply: 24 VDC / 1 W  
Laser Wavelength: 850 nm  
Pulse Repetition Rate: 300 Hz  
Laser Classification: Class 1  
Complies with IEC 60825-1/A2:2001

CE Made in Germany

Electrical Connections  
1 Supply Voltage +24 VDC  
2 Supply Voltage Ground  
Ye-Gn Protective Ground



optel Optical Communication  
Tel 040 830 99 360 Fax 040 830 99 362  
Service@optel.de www.optel.com

Type: HLS-03 Receiver  
Ser. No.: 123 456 789 /2  
Power Supply: 24 VDC / 2 W  
Detection Wavelength: 850 nm

CE Made in Germany

Electrical Connections  
1 Supply Voltage +24 VDC  
2 Supply Voltage Ground  
Ye-Gn Protective Ground  
3 Relay CO Change Over  
4 Relay NO Normally Open  
5 Relay NC Normally Closed



optel Optical Communication  
Tel 040 830 99 360 Fax 040 830 99 362  
Service@optel.de www.optel.com

Type: HLS-03K Receiver  
Ser. No.: 123 456 789 /2  
Power Supply: 24 VDC / 2 W  
Detection Wavelength: 850 nm

CE Made in Germany

Electrical Connections  
1 Supply Voltage +24 VDC  
2 Supply Voltage Ground  
Ye-Gn Protective Ground  
3 Relay CO Change Over  
4 Pre-Alarm Output 22 V / 0 V  
5 Relay NC Normally Closed  
6 Relay NO Normally Open

**Technical Data Receiver Unit HLS-03T**

Receiver Element	Photodiode
Detection Wavelength	850 -904 nm
Minimal Detectable Power	approx. 2 $\mu$ W
Receiver Lens Diameter	38 mm
Field of View (Far Field)	nom. approx. 50 mrad
Alarm Response Time (Relay Release Time)	approx. 2 ms
Alarm Output Pulse Width	approx. 300 - 400 ms
Alarm Relay	
Activation/Permanent/Cut-off Current	max. 5 / 2 / 2 A
Cut-off Voltage	max. 30 VDC / 125 VAC
Cut-off Power	max. 60 W / 125 VA
Operation Indicator 'P'	Green LED
Alarm Indicator 'A'	Red LED
Supply Current (24 VDC)	max. approx. 50 mA
Connecting Cable	Armoured Silicone Cable 6 x 0,75 mm <sup>2</sup>
Cable Length (non-detachable)	2 m
Connector (optional)	9-contacts

**Elektrical Connections**

Lead Number or Colour	Connector Contact	Designation
1	1	Supply Voltage +24 VDC $\pm$ 20%
2	2	Supply Voltage Ground
3	3	Alarm Relay (CO) Change-Over Contact
4	4	Alarm Relay (NO) Normally-Open Contact
5	5	Alarm Relay (NC) Normally-Closed Contact (Contact is closed in alarm mode or when no supply voltage is applied)
Yellow-Green	9	Protective Ground (Internally connected to Supply Voltage Ground)
1 (+ red Ring)	8	VAC - L1 Live (optional)
2 (+ red Ring)	7	VAC - N Neutral (optional)

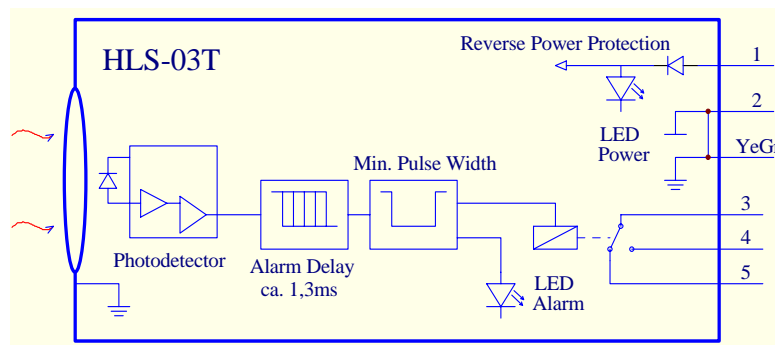

Drawing shows 'Alarm'-Relay in 'Alarm'-mode or with no supply voltage applied.

**Mechanical Outlines**

**Light Barrier Transmitter / Receiver Unit HLS**

Standard Housing and Cooling Jacket Housing

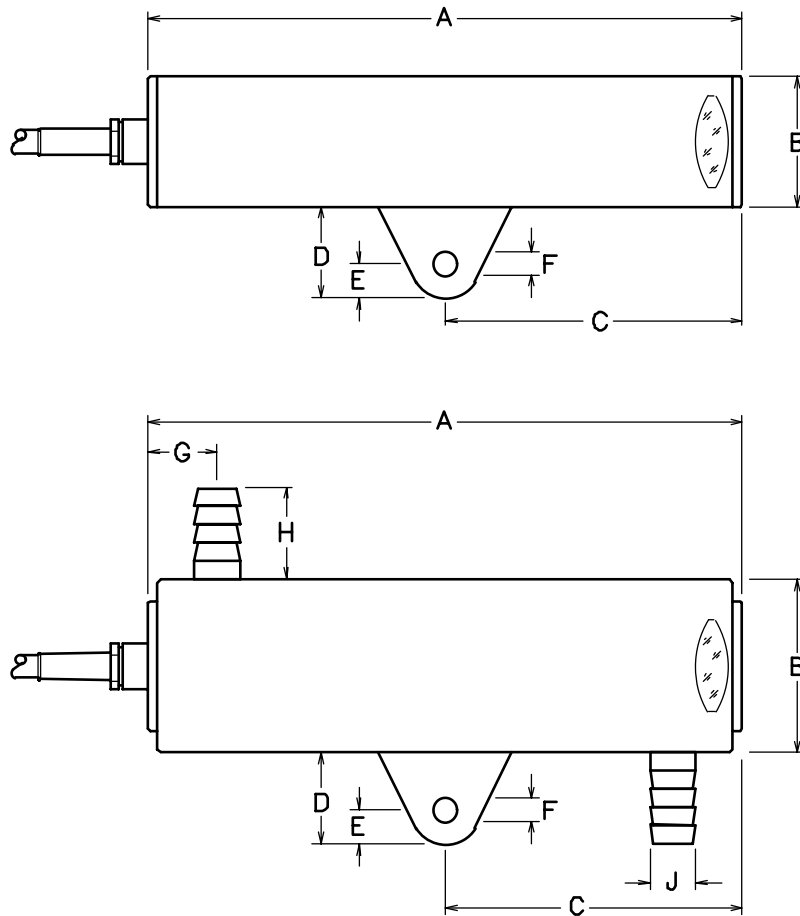

Systems	A	B	C	D	E	F	G	H	J
Standard housing	258	57 $\phi$	129	40	15	10 $\phi$	-	-	-
Cooling Jacket housing		76 $\phi$					30	40	20 $\phi$

All dimensions in mm

HEAVY DUTY LASER LIGHT BARRIER SYSTEM

HLS-03



HLS Light Barrier Transmitter with detachable Cable (optional)



HLS Light Barrier Receiver with detachable Cable (optional)

HEAVY DUTY LASER LIGHT BARRIER SYSTEM

HLS-03



HLS Light Barrier Unit in Double-Walled Cooling Housing with Alignment Mounting



HLS Light Barrier Transmitter "Well used..."

## Contact Data

OPTEL Gesellschaft für Lasertechnik und Elektronik mbH  
Holzkoppel 1 ● D-22869 Schenefeld / Hamburg ● Germany

eMail: [info@optel.com](mailto:info@optel.com)

Tel: +49 (0)40 830 99 360

Fax: +49 (0)40 830 99 362

[www.lightbarrier.de](http://www.lightbarrier.de)

[www.optel.com](http://www.optel.com)

OPTEL-Service

eMail: [service@optel.com](mailto:service@optel.com)

Mobil: +49 (0)172 5154 360